

Market Price of 10kW Energy Storage Battery Cabinet in the United States



Overview

Let's cut to the chase - a 10kW solar battery storage system currently ranges between \$8,900 to \$3,120 depending on configuration and purchase volume. But wait, before you reach for your wallet, there's more to this story than meets the eye. Strong ROI in Specific Markets: 10kW batteries deliver 5-7 year payback periods in markets with high time-of-use rate differentials (like California's NEM 3. Chemistry Matters for. Meta Description: Explore the latest pricing trends for 10kW energy storage batteries, including factors affecting costs, industry applications, and how to choose the right system. Learn why prices vary and discover actionable insights for 2024. What's Driving the Demand for 10kW Energy Storage. Cost Projections for Utility-Scale Battery Storage: 2025 Update. This work was authored by NREL for the. This battery storage update includes summary data and visualizations on the capacity of large-scale battery storage systems by region and ownership type, battery storage co-located systems, applications served by battery storage, battery storage installation costs, and small-scale battery storage. 10 kW Solar Battery Cost: Is It Worth Buying for Your Home Energy Storage?

A 10 kWh solar battery costs between \$6,500 and \$7,600.

Market Price of 10kW Energy Storage Battery Cabinet in the United



Utility-Scale Battery Storage , Electricity , 2024 , ATB , NLR

Battery cost and performance projections in the 2024 ATB are based on a literature review of 16 sources published in 2022 and 2023, as described by Cole and Karmakar (Cole and Karmakar, 2023). Three ...

[Learn More](#)

Battery Energy Storage Cabinet Cost: A 2025 Breakdown for ...

Let's cut to the chase: battery energy storage cabinet costs in 2025 range from \$25,000 to \$200,000+ - but why the massive spread? Whether you're powering a factory or stabilizing a solar

...

[Learn More](#)



Residential Energy Storage Battery Cabinets Market Size, Landscape

Gain valuable market intelligence on the Residential Energy Storage Battery Cabinets Market, anticipated to expand from USD 7.88 billion in 2024 to USD 25.57 billion by 2033 at a CAGR of ...

[Learn More](#)

10kW Solar Battery Storage Price



Guide: What You Need to Know in ...

Let's cut to the chase - a 10kW solar battery storage system currently ranges between \$8,900 to \$3,120 depending on configuration and purchase volume. But wait, before you reach for your wallet, there's ...

[Learn More](#)



10kW Solar Battery Price Guide 2025: Complete Cost Breakdown

This comprehensive guide breaks down everything you need to know about 10kW solar battery pricing, from individual component costs to long-term return on investment.

[Learn More](#)

U.S. residential battery costs by company 2025, Statista

U.S. dollars as of June 2025. While the most expensive battery storage system was sold by Enphase, APsystems offered the most affordable. Already have an account? Get notified via email ...

[Learn More](#)



10 kW Solar Battery Cost: Is It Worth Buying for Your Home Energy ...

Different brands charge between \$5,000 and \$15,000 for a 10 kW solar battery. The cost varies based on brand

reputation, technology used, and warranty offered. For instance, Tesla offers ...

[Learn More](#)



Understanding 10kW Energy Storage Battery Prices: Costs, Trends, ...

Understanding 10kW energy storage battery prices requires balancing upfront costs with long-term savings. By evaluating factors like battery chemistry, installation, and local incentives, you can make ...

[Learn More](#)

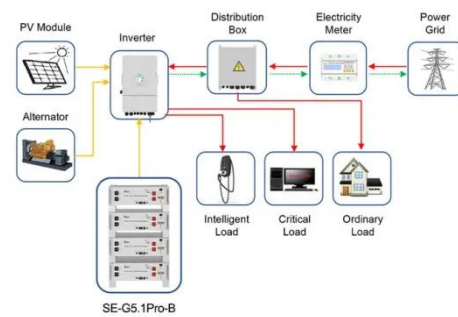

Application scenarios of energy storage battery products



Cost Projections for Utility-Scale Battery Storage: 2025 Update

In this work we describe the development of cost and performance projections for utility-scale lithium-ion battery systems, with a focus on 4-hour duration systems. The projections are developed from an ...

[Learn More](#)

Contact Us

For catalog requests, pricing, or partnerships, please visit:
<https://v4venison.co.za>

